

The role of the depurator is to separate the liquid and solid particles contained in the compressed air with a high degree of efficiency. This separation is carried out using a special filtering element called a "coalescence cartridge".



TECHNICAL DATA	DEP 100	DEP 100	DEP 200	DEP 200	DEP 200	DEP 300	DEP 300	DEP 300	
Threaded port	G 1/4	G 3/8	G 1/4	G 3/8	G 1/2	G 1/2	G 3/4	G 1"	
Degree of filtering	99.97% at 0.01 µm								
Max. inlet pressure	MPa	1.5			1.3				
	Bar	15			13				
	psi	217			188				
Maximun suggested flow rate	Please look at the flow rate curves at page 3.1/33								
Suggested flow at 6 bar	Nl/min	230	360		500				
Fluid	5µm filtered air								
Max temperature	°C	50							
	°F	122							
Weight	Kg	0.4	0.9		1.4				
Wall fixing screws		M4 x 50	M5 x 60		M5 x 70				
Mounting position		Vertical							
Bowl capacity	cm ³	22	45		75				
Drain		Manual/Semi-auto (RMSA)			Manual/Semi-auto (RMSA)				
		Automatic (SAC)			Automatic (RA)				
Notes on use	It is advisable to mount a 5mm pre-filter in order to separate the solid particles first.								
	The maximum inlet pressure for the version with RA automatic condensate drainage must not exceed 10 bar.								

HOW THE COALESCENCE CARTRIDGE WORKS

Air from the mains – full of impurities – flows into the coalescence cartridge and then passes through the crossed micro-fibres that make up the cartridge. During this movement the liquid particles come into contact with the crossed micro-fibres and adhere to them. Due to the air pressure and gravity they join up with other micro-drops at each cross-over point and gradually increase in volume, leading to the physical phenomenon called coalescence. When they stop moving, the drops deposit on the outside of the cartridge, from which they detach and drop to the bottom. Since the volume of liquid leaving the cartridge is exactly the same as the drops arriving, the coalescence cartridge ought to work indefinitely. Solid particles are caught with the same efficiency but, unlike drops, they are not drained out and clog the cartridge. To get round this problem, it is necessary to mount a 5mm pre-filter before the fine oil filter to separate the solid particles first.

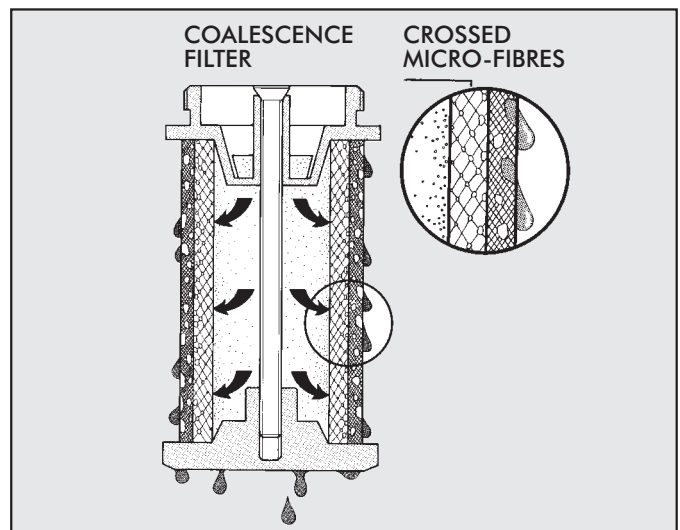

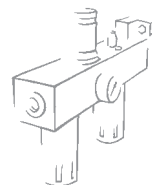

FLOW CHARTS

DEP 100 1/4 - 3/8

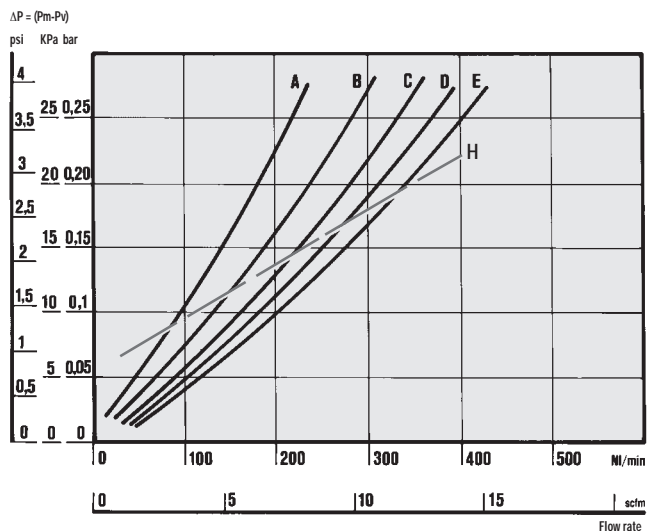

DEP 200 1/4 - 3/8 - 1/2

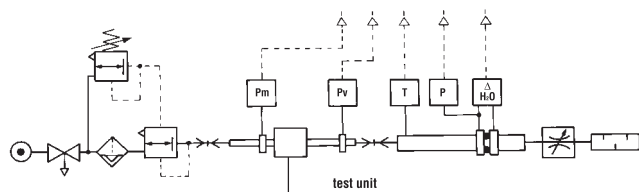
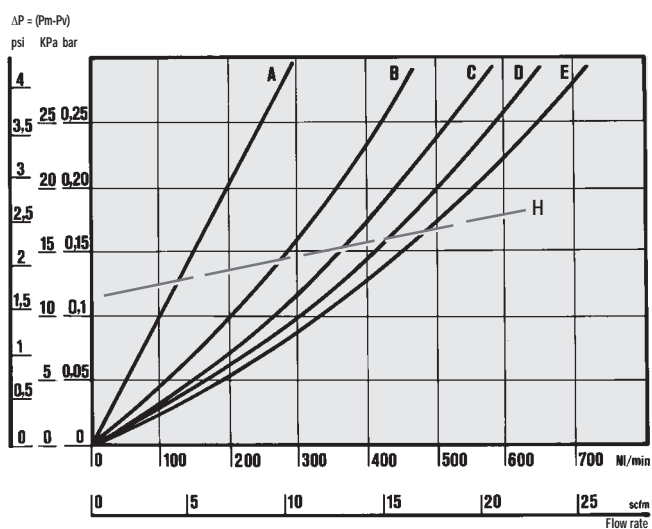

• Flow tests carried out at the Department of Mechanics, Turin Polytechnic, using the computerized test bench following CETOP RP50R recommendations (ISO DIS 6358-2-approved) with ISO 5167 diaphragm gauge.

- (A) = 2 bar - 0,2 MPa - 29 psi
- (B) = 4 bar - 0,4 MPa - 58 psi
- (C) = 6 bar - 0,6 MPa - 87 psi
- (D) = 8 bar - 0,8 MPa - 116 psi
- (E) = 10 bar - 1 MPa - 145 psi
- (H) = maximum flow rate recommended for optimal operation

DEP 300 1/2 - 3/4 - 1

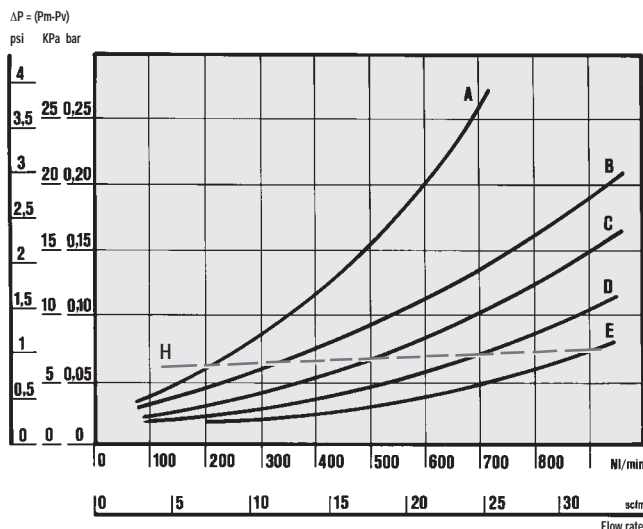

DIMENSIONS

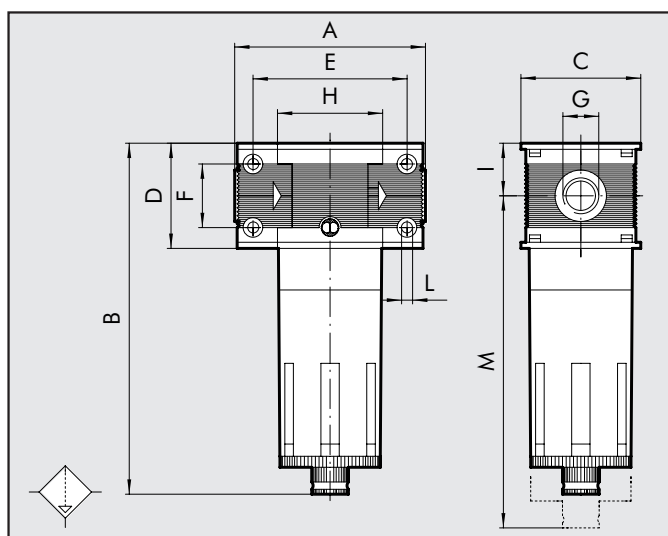

	DEP 100	DEP 100	DEP 200	DEP 200	DEP 200	DEP 300	DEP 300	DEP 300
Th. p.	G 1/4	G 3/8	G 1/4	G 3/8	G 1/2	G 1/2	G 3/4	G 1"
A	78			93.5		110		112
B	144			175			195	
C	50			63			72	
D	43			55			65	
E	63			78.5			92	
F	26			36			42	
G	G 1/4	G 3/8	G 1/4	G 3/8	G 1/2	G 1/2	G 3/4	G 1"
H	43			55.5			65	
I	21.5			27.5			32.5	
L	M4 hole			M5 hole			M5 hole	
M	137			196			215	

Skillair® 400 DEPURATOR

- Coalescence cartridge with a very high degree of filtration
- Metal bowl with bayonet coupling, safety lock and 360° condensate display
- Manual/semi-auto condensate drain
- Optional activated carbon cartridge with 0.003 ppm oil residue (food industry, pharmaceuticals, cosmetics).



TECHNICAL DATA	DEP 400			
	G 1"	G 1"1/4	G 1"1/2	G 2"
Threaded port	G 1"	G 1"1/4	G 1"1/2	G 2"
Degree of filtration	99.99% at 0.01 µm			
Max. inlet pressure	MPa	1.3		
	Bar	13		
	psi	188		
Maximun suggested flow rate	Please look at the flow rate curves at page 3.1/35			
Suggested flow at 6 bar	Nl/min	2300		2250
Fluid	5 µm filtered air			
Max temperature	°C	50		
	°F	122		
Weight	Kg	4.2		5
Wall fixing screws	M6x110			
Mounting position	Vertical			
Drain	Manual/semi-auto (RMSA) - Automatic (RA)			
Bowl capacity	cm³	270		
Notes on use	It is advisable to mount a 5mm pre-filter in order to separate the solid particles first. Series 400 end plates come with a patented system with a rotary sliding end joint to allow the unit to be adapted to the pipe cutting distance (see page 3.1/03). The maximum inlet pressure for the version with RA automatic condensate drainage must not exceed 10 bar.			

DIMENSIONS	LUB 400			
	G 1"	G 1"1/4	G 1"1/2	G 2"
Threaded port	G 1"	G 1"1/4	G 1"1/2	G 2"
A	225÷255			283÷313
B	320			
C	116			
D	105			
E	141.4			
F	80			
G	G 1"	G 1"1/4	G 1"1/2	G 2"
H	105.4			
I	52.5			
L	M6 hole			
M	378			

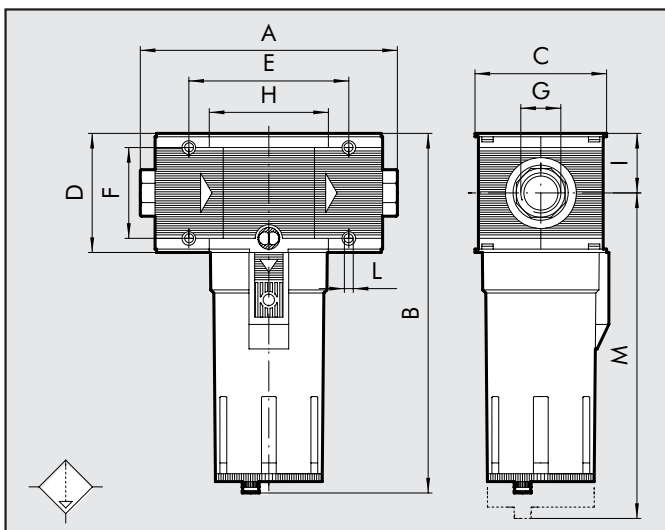

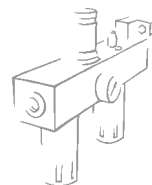

FLOW CHARTS

DEP 400 1''

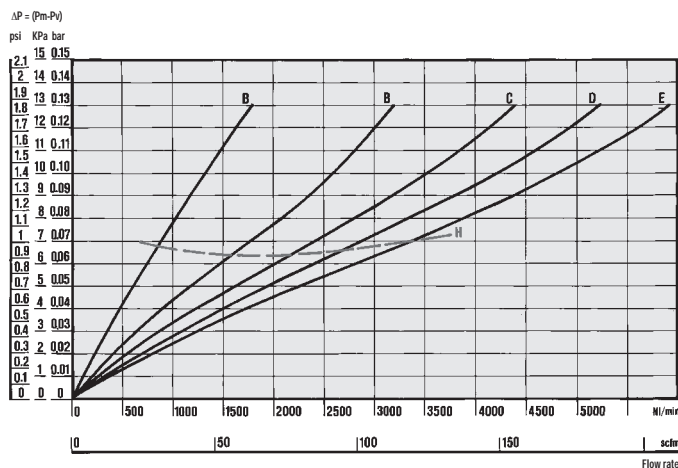

DEP 400 2''

(A) = 2 bar - 0,2 MPa - 29 psi (D) = 8 bar - 0,8 MPa - 116 psi
 (B) = 4 bar - 0,4 MPa - 58 psi (E) = 10 bar - 1 MPa - 145 psi
 (C) = 6 bar - 0,6 MPa - 87 psi (H) = Maximum flow rate recommended for optimal operation.

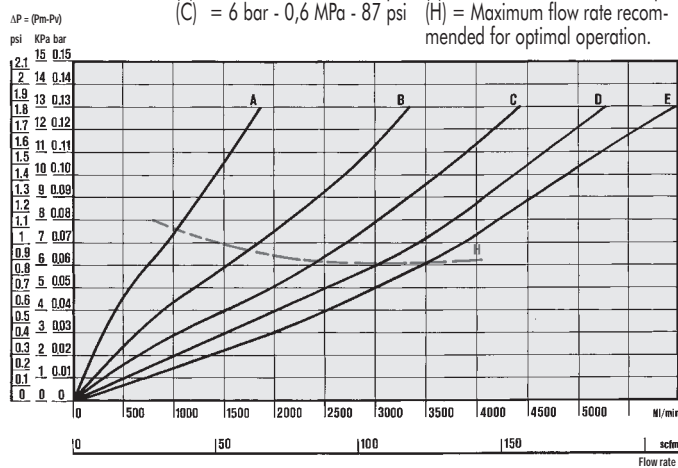

KEY TO CODES

DEP ELEMENT	100 SIZE	1/4 THREADED PORT	RMSA TYPE OF DRAIN
DEP	100	1/4	RMSA
	200	3/8	
	300	1/2	RMSA
	400	3/4	RA
		1	
		1 1/4	
		1 1/2	
		2	

RMSA: Manual/semi-auto drain
 RA: Automatic drain. Float-type operation irrespective of the pressure and flow rate.

ORDERING CODES

Code	Description	Code	Description	Code	Description
SKILLAIR 100 DEPURATOR					
3288001A	D 100 RMSA WITHOUT END PLATES	4488001A	D 300 RMSA WITHOUT END PLATES	6188001A	D 400 RMSA WITHOUT END PLATES
3288002A	D 100 SAC WITHOUT END PLATES	4488002A	D 300 RA WITHOUT END PLATES	6188002A	D 400 RA WITHOUT END PLATES
3288001	D 100 1/4 RMSA	4488001	D 300 1/2 RMSA	6188001	D 400 1 RMSA
3288002	D 100 1/4 SAC	4488002	D 300 1/2 RA	6188002	D 400 1 RA
3388001	D 100 3/8 RMSA	4588001	D 300 3/4 RMSA	6288001	D 400 1 1/4 RMSA
3388002	D 100 3/8 SAC	4588002	D 300 3/4 RA	6288002	D 400 1 1/4 RA
SKILLAIR 200 DEPURATOR					
3488001A	D 200 RMSA WITHOUT END PLATES	4688001	D 300 1 RMSA	6388001	D 400 1 1/2 RMSA
3488002A	D 200 SAC WITHOUT END PLATES	4688002	D 300 1 RA	6388002	D 400 1 1/2 RA
3488001	D 200 1/4 RMSA			6488001	D 400 2 RMSA
3488002	D 200 1/4 SAC			6488002	D 400 2 RA
3588001	D 200 3/8 RMSA				
3588002	D 200 3/8 SAC				
3688001	D 200 1/2 RMSA				
3688002	D 200 1/2 SAC				